



İLMAKSAN

HAVALANDIRMA MAKİNA İMALAT SAN. TİC. İTH. İHR. LTD. ŞTİ.



Teknik Özellikler

Technical Specifications

| | KM 4.1 | KM 7.3 | |
|-----------------|-----------------|-----------------|--------------|
| Yükseklik (mm) | 1100 | 1100 | Height |
| En (mm) | 800 | 580 | Width |
| Boy (mm) | 1300 | 1040 | Length |
| Ağırlık (kg) | 425 | 275 | Weight |
| Kapasite(mm) | 0.5 - 1.2 | 0.5 - 1.2 | Capacity |
| Elektrik | 380 V/3HP/50 Hz | 380 V/3HP/50 Hz | Power Supply |
| Elektrik Motoru | 2.2 kw | 1.5 kw | Motor Output |

KM 4.1



KM 7.3

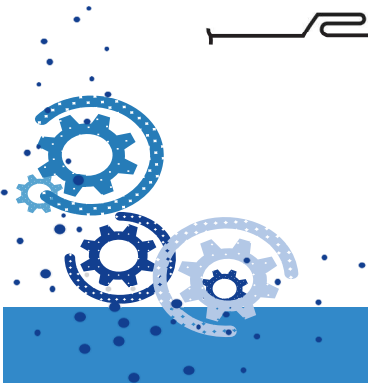

KENET MAKİNASI MODELLERİ ve İŞLEM ŞEKİLLERİ

PITTSBURGH LOCK MACHINE MODELS AND OPERATION SHAPES

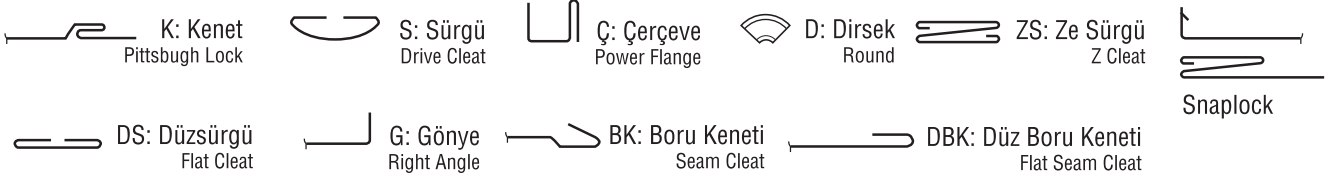

| MODEL | Maksimum kapasite mm | İŞLEM ŞEKİLLERİ / OPERATION SHAPES | MODEL | Maksimum kapasite mm | İŞLEM ŞEKİLLERİ / OPERATION SHAPES |
|-------------------|----------------------|------------------------------------|----------------|----------------------|------------------------------------|
| KM-4.0 K.S.Ç.D | 0.5-1.2 | | KM-2.1 K.S | 0.5-1.2 | |
| KM-4.1 K.S.BK.D | 0.5-1.2 | | KM-2.2 K.G | 0.5-1.2 | |
| KM-4.2 K.D.BK.DS | 0.5-1.2 | | KM-2.3 K.D | 0.5-1.2 | |
| KM-4.3 K.D.DBK.DS | 0.5-1.2 | | KM-2.4 S.BK | 0.5-1.2 | |
| KM-4.4 K.Ç.BK.D | 0.5-1.2 | | KM-2.5 S.D | 0.5-1.2 | |
| KM-4.5 K.S.G.D | 0.5-1.2 | | KM-2.6 K.Ç | 0.5-1.2 | |
| KM-4.6 K.G.Ç.D | 0.5-1.2 | | KM-2.7 K.BK | 0.5-1.2 | |
| KM-4.8 K.S.DBK.D | 0.5-1.2 | | KM-2.8 S.Ç | 0.5-1.2 | |
| KM-3.1 K.S.Ç | 0.5-1.2 | | KM-2.9 S.G | 0.5-1.2 | |
| KM-3.2 K.S.D | 0.5-1.2 | | KM-2.10 Ç.D | 0.5-1.2 | |
| KM-3.3 K.ZS.G | 0.5-1.2 | | KM-2.11 Ç.G | 0.5-1.2 | |
| KM-3.4 K.G.D | 0.5-1.2 | | KM-2.12 G.D | 0.5-1.2 | |
| KM-3.5 K.ZS.S | 0.5-1.2 | | KM-1.13 BK.DBK | 0.5-1.2 | |
| KM-3.6 K.Ç.D | 0.5-1.2 | | KM-1.0 D | 0.5-1.2 | |
| KM-3.7 K.G.S | 0.5-1.2 | | KM-1.1 K | 0.5-1.2 | |
| KM-3.8 K.Ç.G | 0.5-1.2 | | KM-1.2 S | 0.5-1.2 | |
| KM-3.14 K.Ç.BK | 0.5-1.2 | | KM-1.3 Ç | 0.5-1.2 | |
| KM-3.10 K.DS.D | 0.5-1.2 | | KM-1.4 BK | 0.5-1.2 | |
| KM-3.11 K.ZS.BK | 0.5-1.2 | | KM-1.5 DBK | 0.5-1.2 | |
| KM-3.12 K.ZS.DBK | 0.5-1.2 | | KM-1.6 ZS | 0.5-1.2 | |
| KM-3.13 K.G.DS | 0.5-1.2 | | KM-1.7 G | 0.5-1.2 | |
| KM-3.14 K.Ç.DBK | 0.5-1.2 | | KM-1.8 DS | 0.5-1.2 | |
| KM-3.15 K.D.DBK | 0.5-1.2 | | KM-1.9 | 0.5-1.2 | |
| KM-3.16 K.BK.D | 0.5-1.2 | | KM-1.10 | 0.5-1.2 | |

◆ KARE KANAL MAKİNASI DUCT FORMING MACHINE

Teknik Özellikler *Technical Specifications*

| | | |
|---|------------------|--|
| Yükseklik | 1400 mm | <i>Height</i> |
| En | 2100 mm | <i>Width</i> |
| Boy | 2400 + 4350 mm | <i>Length</i> |
| Ağırlık | 2550 kg + 800 kg | <i>Weight</i> |
| Kapasite | 0.5 - 1.2 mm | <i>Capacity</i> |
| Kanal Kapasitesi | min. 125x125 mm | <i>Duct Capacity</i> |
| Elektrik | 380 V/4hp/50 Hz | <i>Power Supply</i> |
| Elektrik Motoru | 3 kw - 1400 d/dk | <i>Motor Output</i> |
| Gerekli Hava Basıncı | 7 Bar | <i>Atmospheric Pressure</i> |
| PLC Kontrollü Ekran | | <i>PLC Monitor</i> |
| Otomasyon Sorunları İçin Uzaktan Yardım Modemi | | <i>Remote Assistance Modem For Automation Problems</i> |

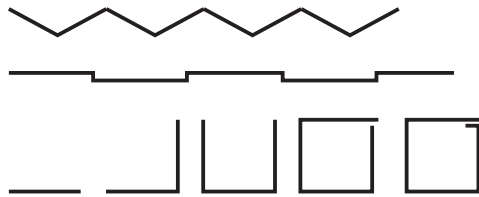
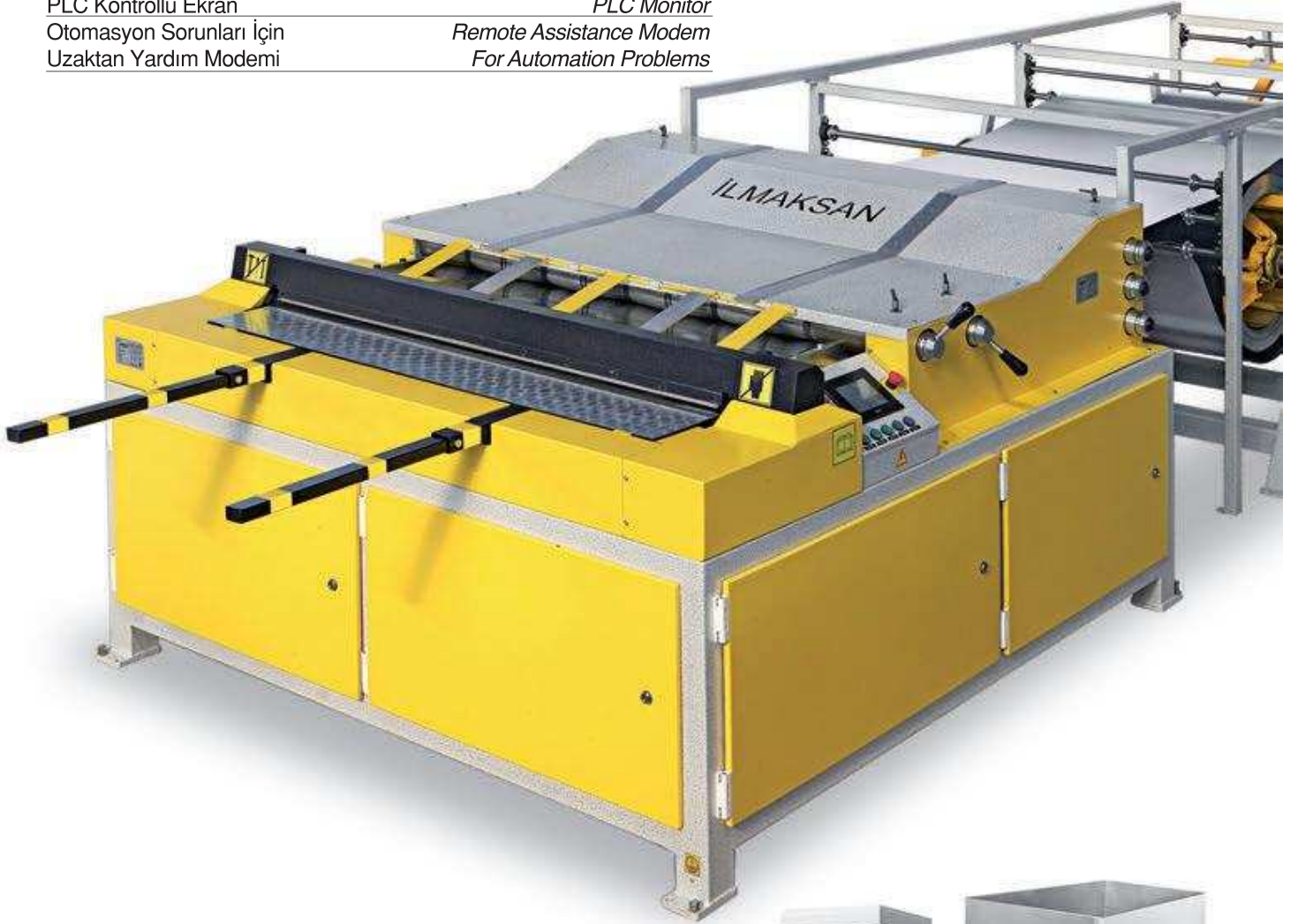

◆ KENET KAPAMA MAKİNASI DUCT ZIPPER MACHINE

Teknik Özellikler

Technical Specifications

| | | |
|-----------------|------------------|--------------|
| Yükseklik | 970 mm | Height |
| En | 600 mm | Width |
| Boy | 4750 mm | Length |
| Ağırlık | 630 kg | Weight |
| Kapasite | 0.5 - 1.2 mm | Capacity |
| Elektrik | 380 V/4HP/50 Hz | Power Supply |
| Elektrik Motoru | 3 kw - 1400 d/dk | Motor Output |

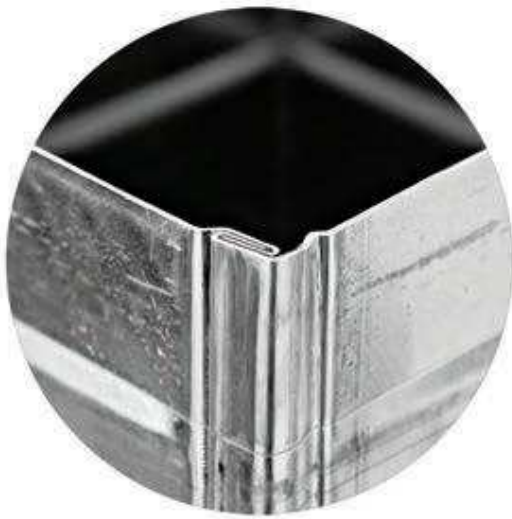



SPİRAL KANAL MAKİNASI

SPIRADUCT MACHINE

Teknik Özellikler

Technical Specifications

| | | |
|-----------------|-----------------|-----------------|
| Yükseklik | 2380 mm | Height |
| En | 3750 mm | Width |
| Boy | 7450 mm | Length |
| Ağırlık | 2000 kg | Weight |
| Kapasite | 0.5 - 1 mm | Capacity |
| Testere Motoru | 4 kw | Saw Output |
| Krom Kapasite | Max. 0.60 mm | Chrome Capacity |
| Çap Aralığı | 80 - 1400 mm | Diameter Range |
| Elektrik | 380 V/4hp/50 Hz | Power Supply |
| Elektrik Motoru | 7.5 kw | Motor Output |

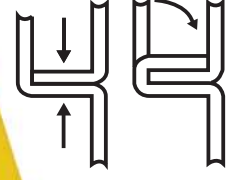
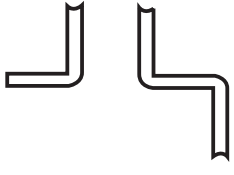

◆ YUVARLAK DİRSEK MAKİNASI *ELBOW MAKER*

| Teknik Özellikler | Technical Specifications | |
|--------------------------|---------------------------------|---------------------------|
| Çap aralığı | 125 - 1250 mm | <i>Diameter</i> |
| Sac Kalınlığı | 0.40 - 1.20 mm | <i>Material Thickness</i> |
| Segment Açısı | 30 c° | <i>Segment Angle</i> |
| Yükseklik | 1200 mm | <i>Height</i> |
| En | 750 mm | <i>Width</i> |
| Boy | 2550 mm | <i>Length</i> |
| Ağırlık | 750 kg | <i>Weight</i> |
| Elektrik | 380 V/4kv/50 Hz | <i>Power Supply</i> |
| Hidrolik Tank | 65 lt | <i>Hydraulic Tank</i> |

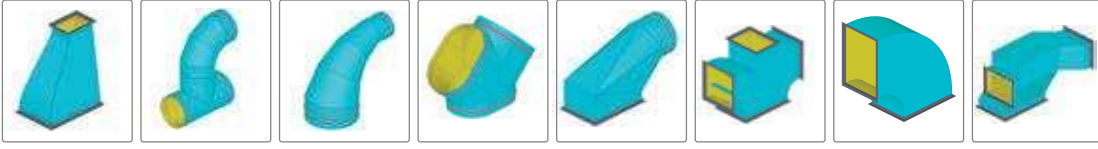

◆ PLAZMA PLAZMA

Teknik Özellikleri *Technical Specifications*

| | | |
|----------------|----------------|---------------------|
| Yükseklik | 1500 mm | <i>Height</i> |
| En | 2250 mm | <i>Width</i> |
| Boy | 4500 mm | <i>Length</i> |
| Ağırlık | 990 kg | <i>Weight</i> |
| Elektrik Motor | 400 Watt Servo | <i>Power Supply</i> |
| Kapasite | 3400 - 1500 | <i>Capacity</i> |
| Hava Basıncı | 6 bar | <i>Air Pressure</i> |

Makinayı Oluşturan Gruplar

- Dokunmatik ekranlı bilgisayar
- Curuf toplama çekmececi
- Mach 3 plazma kesim programı
- Camduct-map yerleşim programı
- Plazma kesim jenaretörü
- Egzos çıkışı
- Hareketli köprü
- Servo kontrol sistemi
- Liner kızak



◆ RULO TAŞIYICI *DECOILER*

Teknik Özellikler *Technical Specifications*

| | | |
|------------------|----------------|--------------------------------|
| Model | RT 1500 | <i>Model</i> |
| Maks. Rulo Ağır. | 5000 kg | <i>Max. Weight of Coil</i> |
| Maks. Rulo Eni | 1500 mm | <i>Max. Widht of Coil</i> |
| Rulo İç Çapı mm | 450-650 | <i>Inside Diameter of Coil</i> |
| Makina Ağırlığı | 260 kg | <i>Weight</i> |



◆ FLANŞ KESME MAKİNASI FLANGE CUTTING MACHINE

| Teknik Özellikler | Technical Specifications | |
|-------------------|--------------------------|--------------|
| Yükseklik | 1200 mm | Height |
| En | 650 mm | Width |
| Boy | 500 | Length |
| Ağırlık | 115 kg | Weight |
| Elektrik | 380 V / 1,5 kw / 50 Hz | Power Supply |
| Hava Basıncı | 6 bar | Air Pressure |

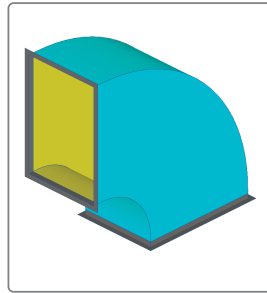

◆ SANTİM MAKİNASI FLANGING MACHINE

| Teknik Özellikler | Technical Specifications | |
|-------------------|--------------------------|--------------|
| Yükseklik | 1250 mm | Height |
| En | 520 mm | Width |
| Boy | 520 | Length |
| Ağırlık | 140 kg | Weight |
| Elektrik | 220 V/0.75 kw/50 Hz/13 A | Power Supply |
| Saç kalınlıkları | 0,5 - 1,2 mm | |



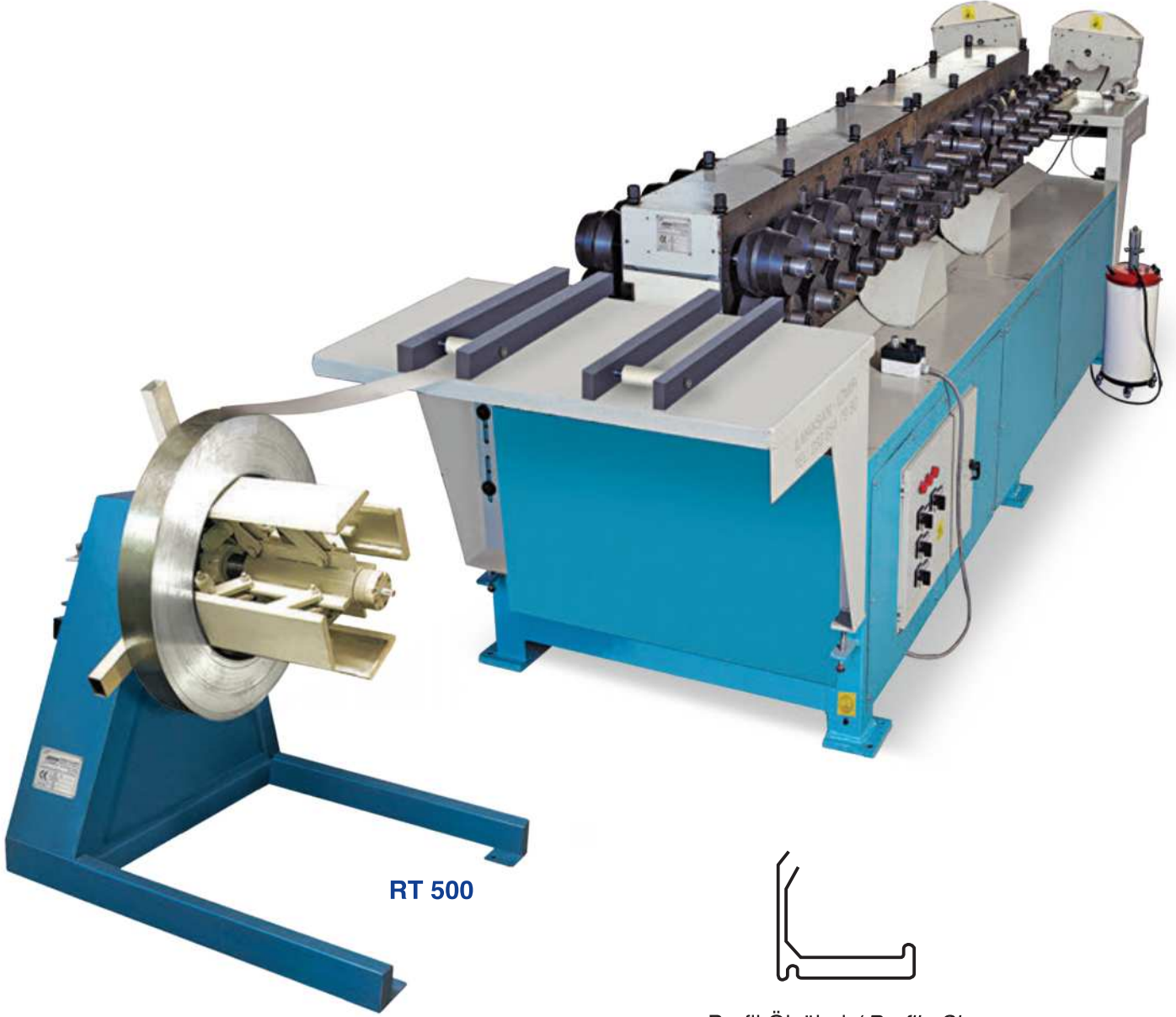

RT 500

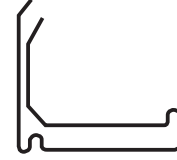

Profil Ölçüleri / Profile Size
20 - 25 - 30 - 35

◆ **FLANŞ MAKİNASI** *FLANGE MACHINE*

| Teknik Özellikler | Technical Specifications | |
|--------------------------|---------------------------------|---------------------|
| Yükseklik | 1200 mm | <i>Height</i> |
| En | 1150 mm | <i>Width</i> |
| Boy | 5500+4000 mm | <i>Length</i> |
| Ağırlık | 2400 kg | <i>Weight</i> |
| Elektrik | 7.5 kw | <i>Power Supply</i> |
| Kapasite | 0,60 - 0.80 mm | <i>Capacity</i> |

CAKA MAKİNASI

HAND OPERATED FOLDING MACHINE

Teknik Özellikler

Technical Specifications

| Model | En Width | Boy Length | Yükseklik Height | Ağırlık Weight | Çalıştırma Genişliği Working Width | Bükme Kapasitesi Folding Capacity | Max. Bükme Açısı Max. Folding Angle |
|-------|-------------|---------------|---------------------|-------------------|---------------------------------------|--------------------------------------|--|
| 1.0 | 910 mm | 2000 mm | 1350 mm | 250 kg | 1000 mm | 1.20 mm | 135 ° |
| 1.5 | 910 mm | 2500 mm | 1350 mm | 320 kg | 1500 mm | 1.20 mm | 135 ° |
| 2.0 | 910 mm | 3300 mm | 1350 mm | 490 kg | 2100 mm | 1.20 mm | 135 ° |
| 2.5 | 910 mm | 3700 mm | 1350 mm | 600 kg | 2500 mm | 1.20 mm | 135 ° |
| 3.0 | 910 mm | 4160 mm | 1350 mm | 925 kg | 3000 mm | 1.20 mm | 135 ° |



ZİKZAK MAKİNASI

Z PROFILE

Teknik Özellikler

Technical Specifications

| Model | En Width | Boy Length | Yükseklik Height | Ağırlık Weight | Kapasite Capacity | Elektrik Power Supply | Elektrik Motoru Motor Output |
|---------|-------------|---------------|---------------------|-------------------|----------------------|--------------------------|---------------------------------|
| ZP 1.25 | 480 mm | 1650 mm | 1050 mm | 180 kg | 0.40 mm- 1.20 mm | 380 V/0.5 hp/50Hz | 0.37 kw |
| ZP 2.0 | 480 mm | 2370 mm | 1115 mm | 245 kg | 0.40 mm- 1.20 mm | 380 V/0.5 hp/50Hz | 0.37 kw |
| ZP 2.5 | 480 mm | 3950 mm | 1115 mm | 320 kg | 0.40 mm- 1.20 mm | 380 V/0.5 hp/50Hz | 0.37 kw |



İLMAXSAN

MAKİNA İMALAT SAN. TİC. İTHALAT İHRACAT LTD. ŞTİ.

İnönü Mah. Yavuz Sultan Selim cad. No: 101

Ayrancılar - Torbalı İZMİR / TÜRKİYE

Tel: +90 232 854 79 80 - 90 • Fax: +90 232 854 77 87

www.ilmaksan.com.tr • www.ilmaksan.com

e-mail: info@ilmaksan.com.tr • info@ilmaksan.com

Yetkili Bayi